



# **BANLAW**

UNIFY YOUR FUEL SUPPLY

## **PRODUCT AND SERVICES GUIDE**



Pioneers of  
Unified Fuel  
Management

[banlaw.com](http://banlaw.com)

(VERSION **FIVE**)

# PIONEERS OF UNIFIED FUEL

HIGH SPEED  
FILLING SYSTEMS  
& COMPONENTS

MECHANICAL  
& ELECTRICAL  
ENGINEERING

SYSTEMS SOFTWARE  
& ERP INTEGRATION

FUEL MANAGEMENT  
& SECURITY

ACCURATE &  
SAFE REFUELLING



# FUEL MANAGEMENT (UFM)

FUEL SYSTEMS SERVICING  
& MAINTENANCE

PROJECT  
MANAGEMENT  
EXPERTISE

ENVIRONMENTAL  
ACCOUNTABILITY

CARBON EMISSION  
MANAGEMENT & TAX REPORTING

FUEL CLEANLINESS

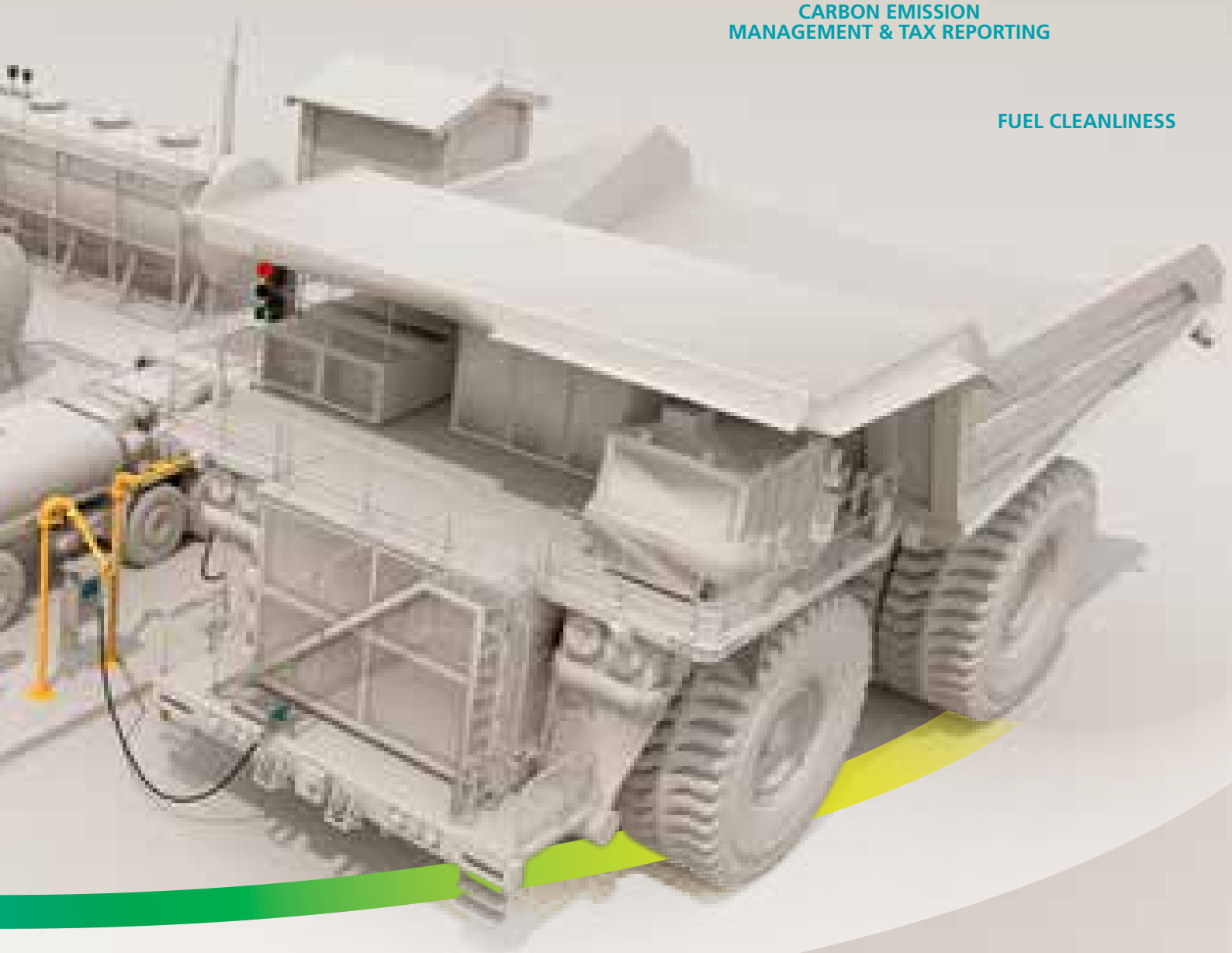

## **Barrick Gold Global**

(Multiple large, complex sites)

In 2010, Barrick Gold selected FuelTrack™ as their Global fuel management system. Now, Banlaw manage 14 Barrick sites across five countries with more than 400 million litres p.a. of diesel measured and accounted for with a level of accuracy not previously possible. The use of FuelTrack™ Enterprise software enables Barrick to develop a globally coherent view of their fuel systems – all from the head office in Toronto, Canada. Barrick have also selected Banlaw to service their entire fuel infrastructure based on Banlaw's specialist expertise.

# OUR EXPERTISE

Join these industry leaders in mining, rail, port and road transport sectors who have looked to Banlaw for their Refuelling Management Systems;

- Abi Group
- Anderson Group
- Anglo American
- Anglo Coal
- AngloGold Ashanti
- ArcelorMittal
- Atlas Copco
- Bard Engineering
- Barrick Gold
- Boulderstone
- Bell Equipment
- BHP Billiton
- Bucyrus International
- Caterpillar
- Calleja Transport
- Downer Mining
- D P World
- Energy Resources of Australia
- English Rail
- Fortescue Metals Group
- Hitachi
- HWE Mining
- Industrea
- Irish Rail
- JJ Robinson
- KTMB Malaysia
- Komatsu
- KPC Mining Indonesia
- Leighton Mining
- Letourneau
- Liebherr
- Maritime Container Services
- Mauritania Rail
- MMG
- Muswellbrook Coal Co
- Newcrest Mining Ltd
- Orica
- Pacific National
- Peabody Resources
- Perilya Mine
- QR National
- RailCorp
- Rio Tinto Aluminium
- Rio Tinto Coal
- Rio Tinto Iron Ore
- Sandvik
- Scottish Rail
- SRH Milk Haulage
- Taiwan Rail
- Thiess Contracting
- Translink Northern Ireland Railway
- United Group Rail
- Vale
- Xstrata
- Yancoal

## KPC Sangatta

(Large, complex site)

KPC commissioned the largest Banlaw installation to date with over 50 Banlaw FuelTrack™ depot consoles on one site in October 2009.

Banlaw's patented Banlaw FuelTrack™ Auto ID system is successfully installed on and tracking over 2000 mine vehicles including heavy, light and contractor vehicles. Fuel accountability is consistent at 99.98% of their 630 million litres per year, or 1.7 million litres a day. Banlaw facilitated a new point of custody transfer agreement with KPC's fuel supplier and is providing a full ongoing Service Level Agreement through local partner Atlas Copco Fluidcon. Banlaw FuelTrack™ System payback period was 6 months.



# CONTENTS

Introduction to Products and Services ...	Page 2
Fuel Management System .....	Page 6
Non-pressurised Overfill Protection .....	Page 8
Dry Break Refuelling.....	Page 10
Nozzle Holsters & Anchors .....	Page 14
Loading Arms & Break Away Valves...	Page 15
Filtered Vents .....	Page 16
Standard Vents .....	Page 18
Accessories .....	Page 20
Check Valve Fuel Receiver .....	Page 21
Oil Couplings - Flush Face Range.....	Page 22
Oil Couplings - Classic Range.....	Page 26
Underground Refuelling .....	Page 28



A photograph of an industrial facility, likely a refinery or chemical plant. In the foreground, there is a large, grey metal control cabinet with a screen and buttons. Behind it, a complex network of pipes and structural steel is visible. In the background, several large, cylindrical storage tanks are situated under a clear sky. The ground is a reddish-brown color, suggesting an arid environment. A white circular callout box is overlaid on the right side of the image, containing text about audit services. A thin blue line extends from the top left corner of the page towards the callout box.

## AUDIT SERVICES

Reduce your risk and get Banlaw, the Unified Fuel Specialists, to audit your site and ensure you're managing your fuel efficiently and effectively. A system audit and gap analysis from our specialist staff enables you to easily compare your current position to best practice and develop integrated solutions customised to your budget.



# PRODUCTS AND SERVICES

## MECHANICAL AND ELECTRICAL ENGINEERING SERVICES

Having quality refuelling products is a great start to managing your fuel but if they are not integrated with each other and into your operations it is wasted money. Time and again companies install new equipment that actually reduces their refuelling flow rates.

Banlaw's dedicated mechanical and electrical engineering specialists are experts in making sure your metering, flow rates, pressure, air-elimination, temperature correction and filtrations systems and products are integrated and customised to achieve the best fuel management outcomes possible on site.

Banlaw invests significant resources into its product and system research, development and quality. Our Quality Assurance System is accredited by Lloyds Register to AS/NZS ISO9001.

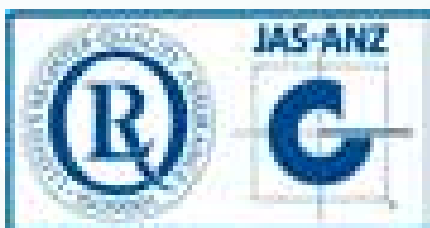

## SOFTWARE DEVELOPMENT

Banlaw is an expert in the critical area of software development. The most difficult aspect of fuel management is ensuring accurate data capture.

Banlaw's team of specialist developers ensure software is customised to improve its compatibility with existing reporting systems and processes. A range of wired and wireless data collection solutions are possible in a range of formats including cards, pins and tags. Banlaw's enterprise software system allows reporting to be done from a regional or head office instead of at each mine, saving considerable reporting time and effort.

## PROJECT MANAGEMENT

The team at Banlaw can manage part of or your entire hydrocarbon management project.

With our in-depth knowledge of fuel management we have the ability to develop a complete fuel storage area and distribution systems from the civil works to the installation and commissioning of tank farms, receivable and distribution areas as well as equipment. Banlaw work with your site managers and staff to implement new systems efficiently and effectively. Training, ongoing monitoring and reporting can all be taken care of for you. Banlaw has its own expert project staff as well as a number of consulting and contract partners to allow it to undertake major projects anywhere in the world.



**BANLAW'S  
HIGHLY SKILLED AND  
EXPERIENCED TECHNICIANS  
ARE UP TO DATE WITH THE  
LATEST MINE SAFETY AND  
ENVIRONMENTAL STANDARDS  
AND OPERATIONS. BANLAW  
STAFF HAVE NEVER HAD AN  
LTI AT A CLIENT SITE IN  
OVER 30 YEARS.**

## **METER CALIBRATION SERVICES**

Making sure that your meters are working effectively will ensure you're not wasting valuable resources. Properly maintaining your meters can also be a legal requirement. The Australian National Measurement Institute requires all meters be inspected and proven on a six monthly basis.

# PRODUCTS AND SERVICES

## REFUELLING FACILITIES MANAGEMENT

If you want to stay on top of your fuel management without employing your own fuel administrator, Banlaw's expert staff can be a more efficient and cost effective alternative. They can be based on site or come in to conduct periodic inspections, maintenance and calibrations. There is often a benefit in having an independent third party manage your facilities, separate from your fuel supplier and your staff.

Banlaw's facilities management and maintenance services are supported by a global help desk servicing Africa to the Americas and staffed by specialists who can solve issues on the spot. The Banlaw Help Desk offers FMS Health Checks that proactively monitors the health of your system, alerting you to issues before you even notice them on the ground.

## REPAIR AND PROGRAMMED MAINTENANCE SERVICE

Your refuelling systems need to be properly maintained to ensure you gain the maximum benefit from them. Regular inspection is also a legislative requirement in some countries for some systems.

After installing new systems, Banlaw can execute a service agreement to make ongoing support cost effective and efficient so you get the most from your new system or we are on call to visit just when you need us.

## REFUELLING COMPONENTS AND SYSTEMS

**Banlaw FuelTrack™** provides precise monitoring, reconciliation and centralised reporting of any machine or vehicle's fuel or lubricant use.

**BANLAW REFUELLING SYSTEMS MANUFACTURE A VARIETY OF INDUSTRY LEADING REFUELLING HARDWARE WITH FLOW RATES AS HIGH AS 1000 LITRES PER MINUTE.**

**Banlaw FillSafe™** allows for the transfer of fuel at rates of up to 1000 litres (265 gallons) per minute with zero overfill, zero tank pressure and zero spillage during refuelling.

**Banlaw LubeCentral™** is a scalable system that makes the transfer of oil and other fluids a clean, efficient and safe operation. Easy to use push-to-connect, flush face, oil and coolant fittings will reduce contamination and increase flow rates whilst eliminating spills.

# FUEL MANAGEMENT SYSTEM

YOU CAN'T MANAGE WHAT YOU CAN'T MEASURE

## BANLAW FUELTRACK™

Being able to secure and track fuel and fluid use is vitally important, particularly with high fuel prices. **Banlaw FuelTrack™** puts you back in control with precise monitoring, reconciliation and centralised reporting of any machine or vehicles' fuel or fluid use.

Banlaw's unique, electronic fuel monitoring system provides a secure, efficient and user friendly way to automatically measure and report on the use of fuel and other costly fluids. It is particularly useful for the mining, rail, and heavy transport industries where fuel loss is an expensive problem.

### The system comprises:

- Depot console to monitor and record fuel or fluid distribution data at each refuelling point
- A range of vehicle auto ID systems including:
  - Direct dry break nozzle connection
  - Smart cards
  - Smart-keys
  - Splash-fill RFID
  - ID and keypad entry
- A Windows based application for system configuration, management and reporting

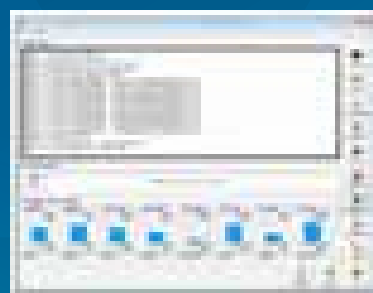

**Banlaw LevelTrack** can integrate with automatic tank gauging equipment to eliminate the need for manual level measurement and aid with fuel reconciliation.

# BUY TO BURN

Banlaw specialises in the design and installations of Industry best practice refuelling systems. Banlaw FuelTrack™ will help you control your fuel inventory from the time fuel is delivered to site until fuel is dispensed to plant equipment.

Verify deliveries, keep track of your current fuel stock and secure your dispensing using Banlaw FuelTrack™.

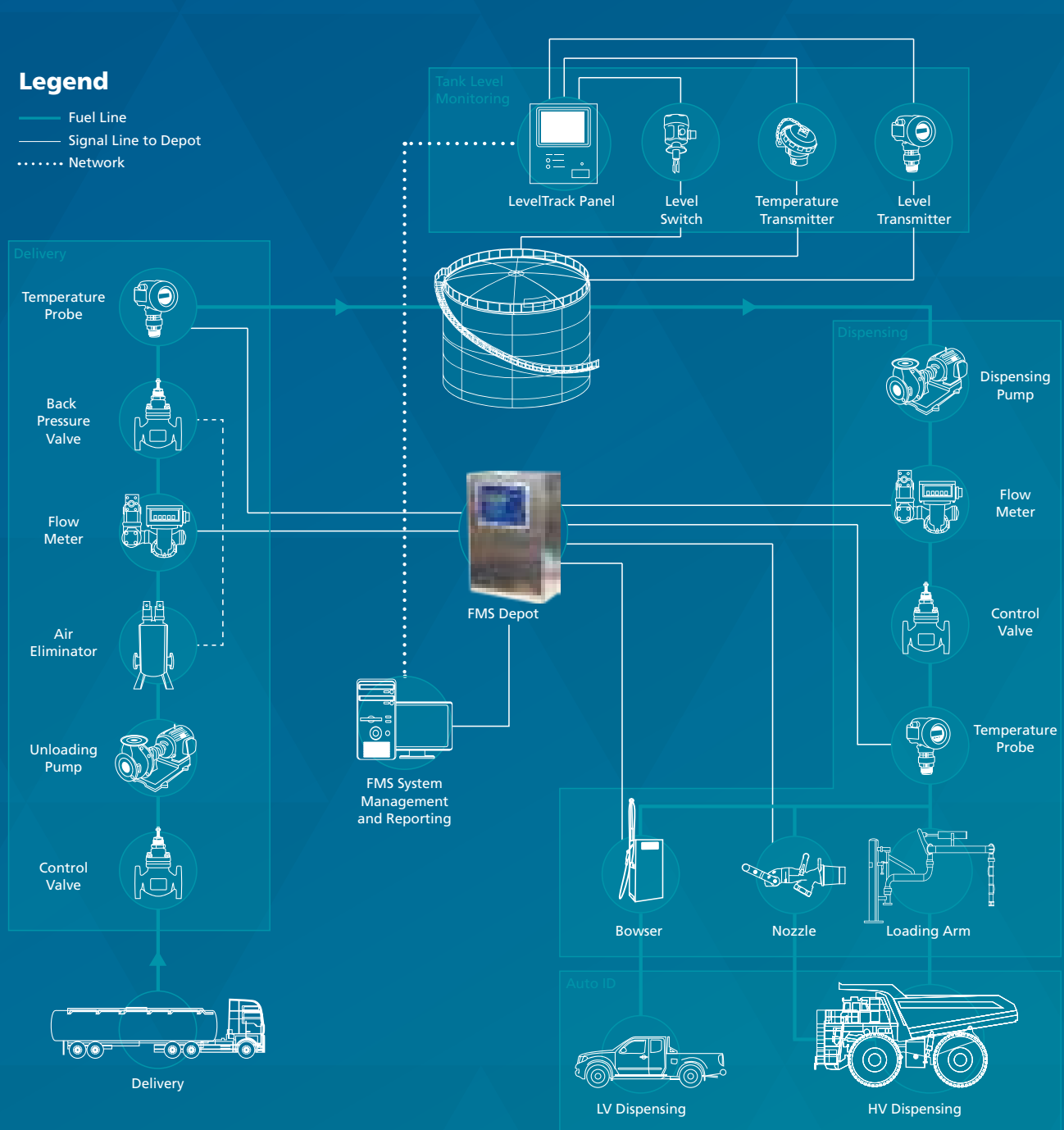

# NON-PRESSURISED OVERFILL PROTECTION

## PRESSURELESS REFUELLING

### BANLAW FILLSAFE™

In today's competitive business world you cannot afford to waste fuel and time. Protecting the safety of staff and the environment is paramount. As the Pioneers of Unified Fuel Management, Banlaw have developed Banlaw FillSafe™ to allow you to transfer fuel and other liquids safely and efficiently.

**Banlaw FillSafe™** ensures zero overfill, zero tank pressure and zero spillage during refuelling in any environment. Rates of more than 1000 litres (264 gallons) per minute can be achieved with no increase in tank pressure.

**Banlaw FillSafe™** is fully electronic and automatic, making it a more reliable system.

**Banlaw FillSafe™** is fully integrated and designed to be a low maintenance asset to all client refuelling applications.

The system components terminate fuel flow once the tank is full. Banlaw FillSafe™ removes the guesswork and manual checking of tank levels when refuelling.

### Advantages for your business

Eliminate the risk of fuel spillage or tank rupture during the refuelling process

- Increases efficiency through faster refuelling times
- Reduce contaminants entering the tank
- Reduce maintenance costs and extend the working life of fuel tanks
- Reduce Occupational Health & Safety related risks from spillages, staff manually checking tanks, and from fire

### Installed onto a variety of mining and rail equipment including:

- Freight and passenger diesel locomotives
- Excavators/shovels
- Haul trucks
- Bulk fluid storage tanks
- Mobile service trucks

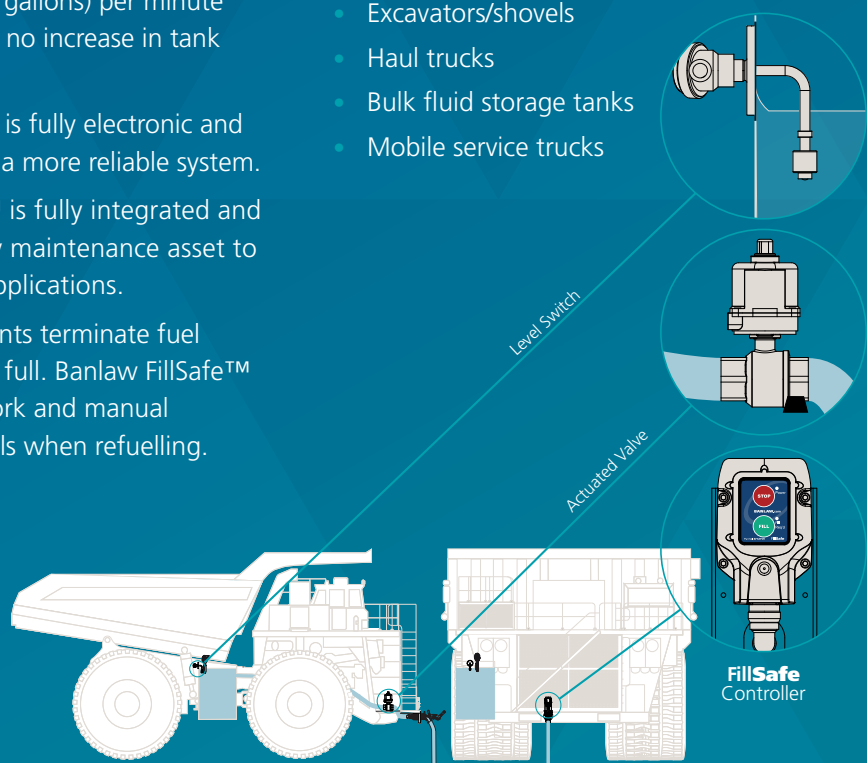

## HYDRAU-FLO®

The Hydrau-Flo® fuel filling system incorporates robustly designed fuel filler safety valves and float control valves to provide a reliable, hydraulically operated arrangement which depends on fluid level rather than pressure. The system is designed to be used in conjunction with existing “high speed refuelling” systems.

Hydrau-Flo® fuel filling valve system:

- Prevents overfilling
- Prevents fuel spillage and wastage
- Removes the risk of tank rupture due to pressure build up during and after filling
- Minimises the risk of fire as a result of fuel spillage
- Reduces costs associated with fuel wastage and equipment damage
- Significantly improves safety and environmental outcomes



# DRY BREAK REFUELLING

## THE WORLD'S TOUGHEST AND SAFEST NOZZLES

We take pride in how well our nozzles perform in some of the harshest working conditions in the world. You can depend on Banlaw nozzles to do the job.

Banlaw nozzles have a proven safety record as our dependable ball locking mechanism ensuring the nozzle cannot 'fly off', risking the safety of the refuelling operator. Banlaw nozzles are designed with the operator of the field task in mind. Our products are easy to carry and manouver, yet robust and reliable.

When refuelling at ground level, an automatic cut-off means the Banlaw nozzle is easier to use and the refuelling operators don't risk climbing onto vehicles, thus reducing the chance of worker injury and compensation.

**The Banlaw Dry Break Automatic cut-off system reduces the risk of fuel spills during the refuel process.**

This results in a refuelling area free from fuel related safety slip hazards. Fitting over load arms, nozzle holsters and nozzle anchors also eliminates trip hazards from ground stored hoses.

With a 2" bore, Banlaw nozzles have the highest industry flow rates capability, reducing refuelling times. The choice of 5 shut-off pressure settings allow faster refuelling times flexible solutions to the most complex refuelling problems.

**The Banlaw nozzle is repairable, not disposable;** they are robust and last considerably longer in the field and can reduce refuelling times. Basically, it costs less in the long run and is built to last.





## 800 SERIES

- Flowrate range for Diesel: 90-800 LPM / 24-211GPM
- Mass (with plug): 3.4kg (7.5lbs)

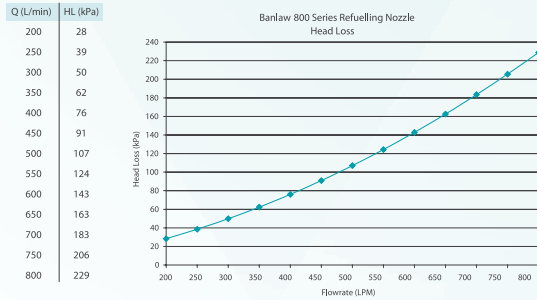

LEGEND:  
 1) All flow tests conducted using DRESOLINE fuel (SG=0.84, 5.5cSt nom.)  
 2) Head Loss (HL) includes Banlaw AUS23 Receiver (results will vary with other make)  
 3) All gauge pressure measured within 2" bore

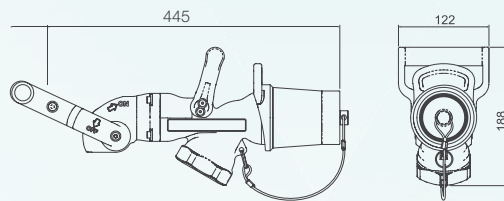

### Related Products

- AUS25A Filter Vent
- BRM23 Receiver



## 1000 SERIES

- Flowrate range for Diesel: 400-900 LPM / 106-264 GPM
- Mass (with plug): 4.3kg (9.5lbs)

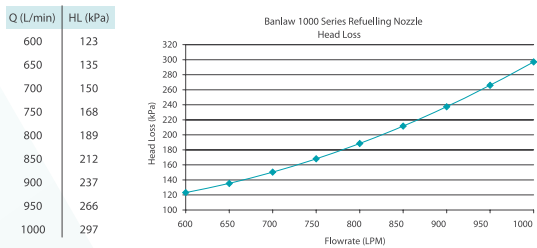

LEGEND:  
 1) All flow tests conducted using DRESOLINE fuel (SG=0.84, 5.5cSt nom.)  
 2) Head Loss (HL) includes Banlaw AUS43 Receiver  
 3) All gauge pressure measured within 2" bore

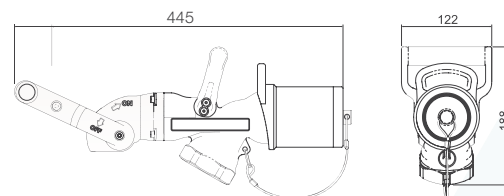

### Related Products

- AUS25A Filter Vents with AUS25AA-1 Coupling
- 2 Vents Required
- BRM43 Receiver



## RAIL

Banlaw provides integrated hydrocarbon management systems, products and expert advice to help rail companies improve their productivity by reducing fuel loss, reducing fuel contamination, as well as ensuring faster, safer refuelling.

Whilst dry break refuelling is not a new phenomenon in the rail industry, pushing the boundaries for refuelling rates and safety is.

Banlaw continues to strive to assist our clients with innovative products and systems to improve refuelling efficiencies and protect the environment at fuelling locations across the globe.

Unique to Banlaw is a range of rail industry designed fuelling components that allow our clients to commonly enjoy flow rates of up to 800 litres per minute.

New to Banlaw is the tried and true range of 'AeroQuip' or 'EDCA' style of loco fuel couplings and tank components. We carry a complete range.

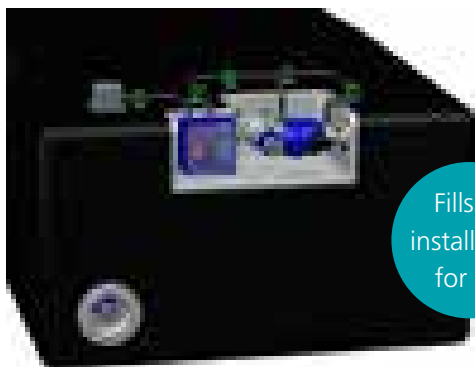

Fillsafe installation for rail



BNR800

If pressureless refuelling is what you are after Banlaw FillSafe™ is also becoming a popular choice of innovative operators and OEM's. This system offers the safety of pressureless refuelling with the added feature of achieving high flow rates.

Banlaw FillSafe™ provides the safe, 'no spill', feature of a pressureless system but with improved efficiencies, unmatched by our rivals, that offer our clients real savings every day.



AUS23R Receiver



AUS25R Vent



AUS25AA-1 Coupling



**RAIL COMPANIES AROUND  
THE WORLD ARE BENEFITING  
FROM BANLAW'S QUALITY  
PRODUCTS AND ITS EXPERT  
KNOWLEDGE AND SYSTEMS**



## NOZZLE HOLSTERS

### REDUCE INCIDENTS AND SAVE MONEY

Drive-aways not only risk serious damage to the fuel dispensing system, but may also cause fuel spillage and the risk of injury to bystanders.

The latest range of Banlaw Nozzle Holsters provide much improved reliability and are designed to withstand harsh operating conditions encountered in mining applications. Holsters are available to suit with 800 or 1000 series in "Fixed stand" or "Service Truck" versions.



An internal electronic proximity switch within the holster detects whether the refuelling nozzle is safely stored into the holster.

This proximity switch can then be used to initiate or control visual and/or audible alarms to alert the driver that the refuelling nozzle remains connected to the vehicle.

## NOZZLE ANCHORS

### SECURE YOUR NOZZLES

Eliminate the trip hazard of a ground-stored nozzle. Secure your nozzles with a Nozzle Anchor.



## FUEL LOADING ARMS

### MORE BENEFITS THAN JUST SAVING YOUR BACK

Banlaw installs & fully commissions each arm with a variety of fuel dispensing equipment which has established a reputation for its rugged design, performance, safety and reliability over 30 years.

The Banlaw Fuel Loading Arm supports the weight of the hose and refuelling coupling which minimises the operator manual handling loads and provides the best opportunity to optimise the dispensed flowrate of the fuel. Up to 1000lpm can be achieved.

Slip and trip hazards are minimised as the hose is not left on the ground which also reduces wear and tear on the hose, ultimately leading to less maintenance and increases the hose service life.

Tailored design to suit a variety of applications, including fixed refuelling bays and mobile service trucks.

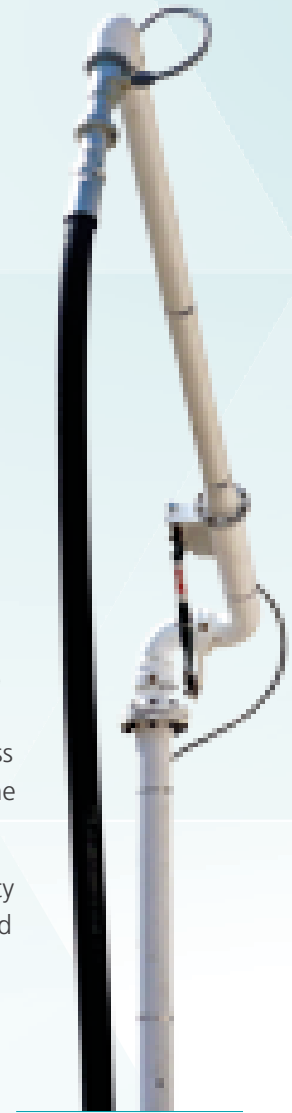

## BREAK AWAY VALVES

### PROTECTING THE LIFE OF YOUR EQUIPMENT

The Banlaw break away valve (BAV) is designed to provide a means of both protecting refuelling system components from damage and preventing spillage of fuel in the event of a vehicle drive-away.

The 3 shear studs connecting each half of the valve are designed to fracture at a certain stress, allowing the valve assembly to separate into 2 dry break components.



AUS4W-50  
Breakaway  
Valve

# FILTERED VENTS

## REDUCES PARTICLES ENTERING THE FUEL SYSTEM

Banlaw has a wide range of vents built from high-grade materials for the ultimate in strength and durability.

Our vent systems provides overfill protection by determining the refuelling systems shutoff level. The vent mechanism guarantees sealing under filling and prevents fuel spillage or leakage from the tank.

Heavy equipment typically operates in dusty, dirty conditions. A generic Quick-Fill tank vent has no means of preventing airborne contamination entering a tank, unlike the Banlaw Filtered Vent which comes with a serviceable air filter within the vent cap. This filter protects against particles entering the tank via the vent, and thus entering the fuel system of the equipment. The service life of OEM fuel filters is extended, reducing the risk of blocked filters and equipment downtime.

### Key Benefits

- Maintaining low emissions
- Maintaining engine performance
- Optimising fuel efficiency
- Reduced maintenance intervals of fuel filters

## ULTRA FINE FILTERED VENT

A complete vent assembly with all the key functions integrated into the one product.

The integrated Banlaw Ultra-Fine Filtered Vent greatly reduces the unwanted ingress of dust and other particulates into the fuel tank via air flow, especially during fuel usage. With modern and up coming diesel engines calling for a low level of particulates in their fuel before performance and engine life is compromised, the Banlaw Ultra-Fine Filtered Vent has been designed fit for purpose.

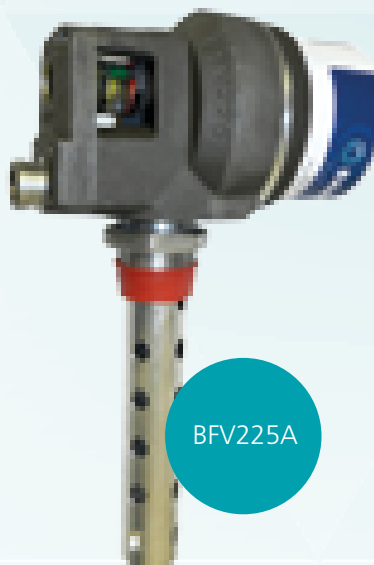

BFV225A

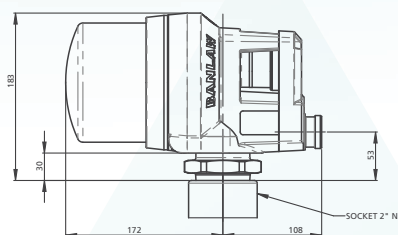
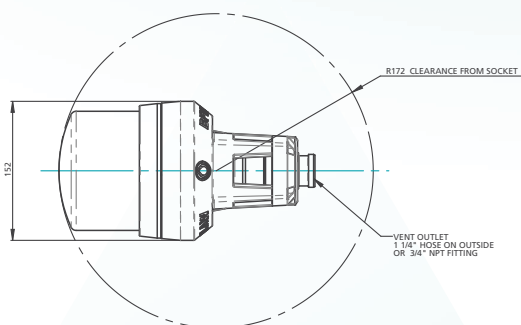

## 16 PSI FILTERED VENT

Suitable for flat or round top fuel tanks.

This vent system provides overfill protection by determining the refuelling systems shutoff level. The vent mechanism guarantees sealing under filling and prevents fuel spillage or leakage from the tank.



BP125A

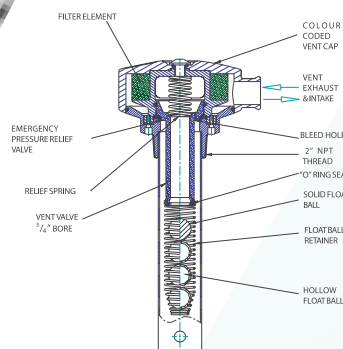

# STANDARD VENTS

## INDUSTRY LEADING TANK VENTS

### Flexible vent solutions

- A flexible and complete range of vents for all applications and OEMs.

### Faster refuelling

- A Banlaw vent will cater for refuelling rates of 800 LPM (211GPM).

### Rugged construction

- High quality and built tough
- Made from aluminium. No plastic.
- Patented design ensures the correct operation of the float balls at all times
- Reliable and durable o'ring seals provide superior performance and service life. Guaranteed sealing during refuelling.





AUS25A & AUS25A-L

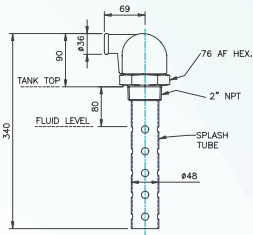

AUS25A and AUS25A-L

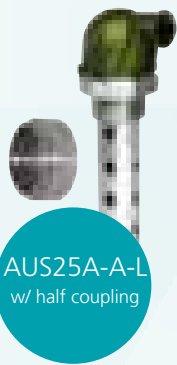

AUS25A-A-L w/ half coupling

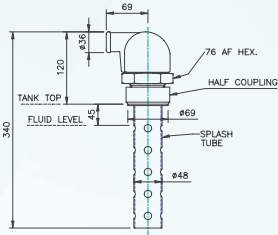

AUS25A-A-L (with half coupling)



AUS25B

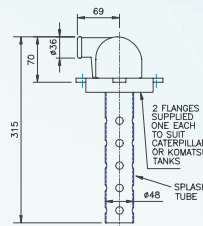

AUS25B

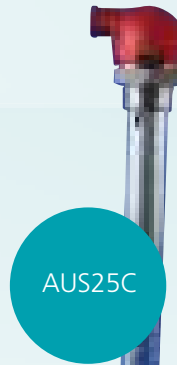

AUS25C

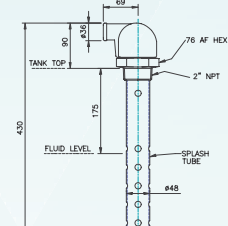

AUS25C

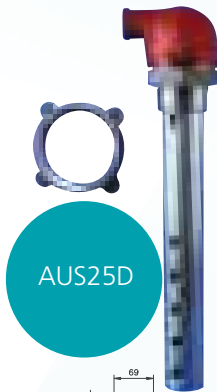

AUS25D

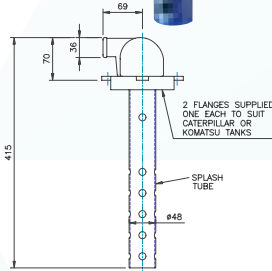

AUS25D



AUS25E-C

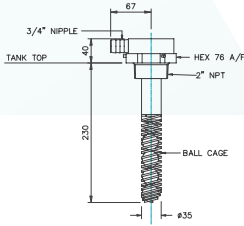

AUS25E-C AND AUS25E-H

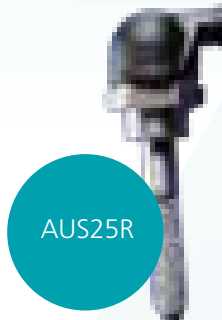

AUS25R

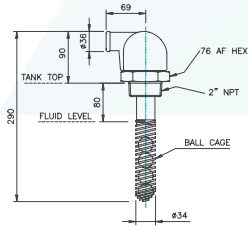

AUS25R

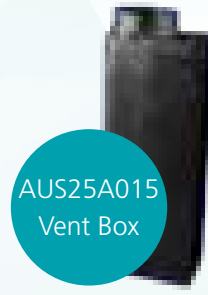

AUS25A015 Vent Box



AUS25AA-1 Vent Half Coupling

## VENT PRODUCT NUMBERS

Vent Configuration	To Suit Flat Top Tanks		To Suit Round Top Tanks		Low Profile Mining		Railways
2" NPT	AUS25A	AUS25A-L	-	-	-	-	AUS25R
2" NPT Extended Vent	-	-	AUS25C	AUS25C-L	-	-	AUS25C-R
With Half Coupling	AUS25A-A	AUS25A-A-L	AUS25C-A	AUS25C-A-L	-	-	-
2" NPT With Hose Tail	AUS25A-C	AUS25A-C-L	AUS25C-C	AUS25C-C-L	AUS25E-H	AUS25E-C	-
Flanged (Tammer Proof)	AUS25B	AUS25B-L	AUS25D	AUS25D-L	-	-	-
Flanged with Hose Tail (Tammer Proof)	AUS25B-C	AUS25B-C-L	AUS25D-C	AUS25D-C-L	-	-	-
Filtered Vent	BP125A	BP125A-L	BP125C	BP125C-L	-	-	BP125R

Vent cap colour indicates relief pressure setting: ■ 110kPa - (16psi) □ 49kPa - (7psi)

\*Note: AUS25E Series Vents supplied only with Gold coloured steel caps

# ACCESSORIES

**ONLY SETTLE FOR THE BEST QUALITY**

High quality accessories to ensure you get the best from your refuelling system.

Banlaw's receivers, swivels, valves and nozzle anchors are made from the highest quality materials like stainless steel, zinc plated steel and anodized aluminium to ensure they withstand harsh everyday treatment.

Caps provide protection when the nozzle and receiver are not connected. Made from aluminium or plastic, they are light and durable.

Prolong the life of your equipment by only using Banlaw accessories.

We recommend the use of caps for all receiver and plugs for all nozzles to protect your equipment and restrict contamination.



AUS10  
Zinc Plated  
Steel Swivel



AUS50  
Anodized  
Aluminium  
Swivels



AUS24A



AUS23-  
SOCKET



AUS4W-50  
Breakaway  
Valve



1000  
Anchor  
AUS22049



800 Anchor  
BP800049

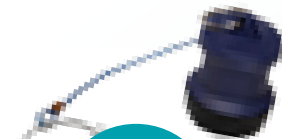

AUS23C  
Cap



AUS43C  
Cap



AUS23C-R  
Cap

**BANLAW**  
UNIFY YOUR FUEL SUPPLY

**REFUELLING NOZZLE INSTRUCTIONS**

**STEP 1**  
1.1 REMOVE RECEIVER CAP  
1.2 REMOVE NOZZLE FROM ANCHOR OR  
1.3 FLUSH FROM FRONT OF NOZZLE  
1.4 ENSURE MATING SURFACES OF RECEIVER  
AND NOZZLE ARE CLEAN AND UNOILSMAZED

**STEP 2**  
2.1 ENSURE OPERATING HANDLE IS  
2.2 LOCKED IN THE OFF POSITION  
2.3 RETURN ACTUATOR AND PISTON  
NOZZLE FULLY ONTO RECEIVER  
2.4 RELEASE ACTUATOR THEN PULL BACK  
ON NOZZLE TO ENSURE SECURE CONNECTION  
2.5 REPEAT STEPS 2.2 AND 2.3 UNTIL  
NOZZLE IS SECURELY CONNECTED

**STEP 3**  
3.1 RELEASE CATCH USING TRIGGER  
AND ROTATE HANDLE INTO ON POSITION  
3.2 NOZZLE WILL AUTOMATICALLY FLOW  
OFF AFTER TANK VENT HAS CLOSED  
3.3 DO NOT MANUALLY HOLD NOZZLE  
IN ON POSITION DURING REFUELLING  
OR AFTER TANK VENT HAS CLOSED  
PROMPTLY REPORT ANY PROBLEMS TO YOUR SUPERVISOR

**STEP 4**  
4.1 ENSURE OPERATING HANDLE  
IS LOCKED IN THE OFF POSITIO  
4.2 RETURN ACTUATOR AND PIS  
NOZZLE FROM RECEIVER  
4.3 REPLACE NOZZLE PLUG  
4.4 REPLACE RECEIVER CAP

Web: [www.banlaw.com](http://www.banlaw.com) Email: [sales@banlaw.com.au](mailto:sales@banlaw.com.au)  
ISO 9001:2008 Phone: 61 2 49226300

AUSOPSIGN-2

# CHECK VALVE FUEL RECEIVER

## THE BEST ANTI-THEFT MECHANISM

The unique design of the Banlaw Check Valve Receiver is unlike any other product on the market.

Banlaw's Check Valve Receiver cannot be overridden, eliminating fuel theft via the receiver.

Intelligent design of the flow path generates low pressure. This prevents the increased risk of premature shut-off of pressure sensitive refuelling nozzles.

Versatile design allows installation either directly into the fuel tank or the pipework (min 2").

Manufactured to exacting standards using high quality materials to withstand harsh operating environments.

The receiver body can be replaced without the need to drain the tank.

Model available to suit Banlaw FuelTrack™ auto ID system.

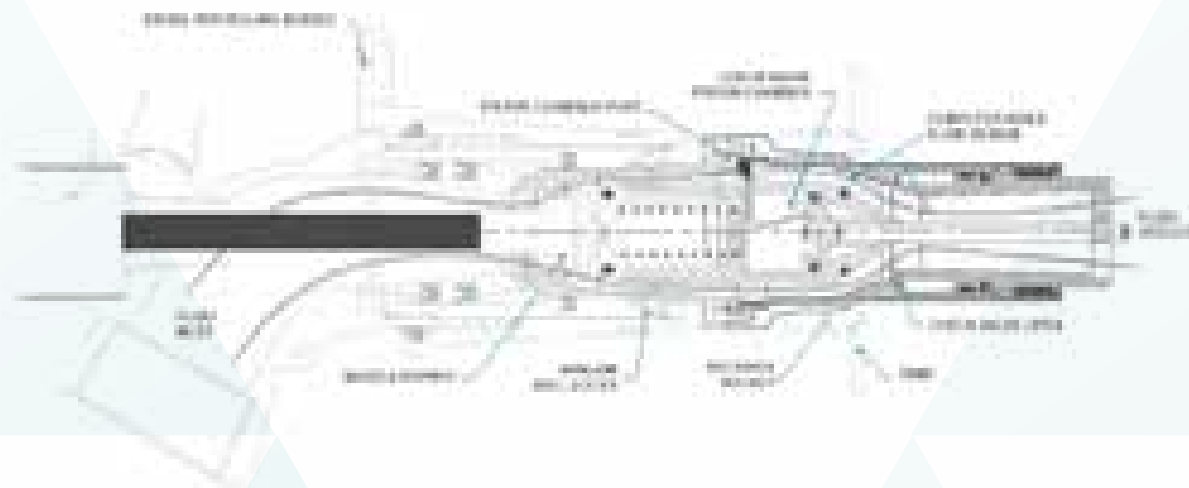
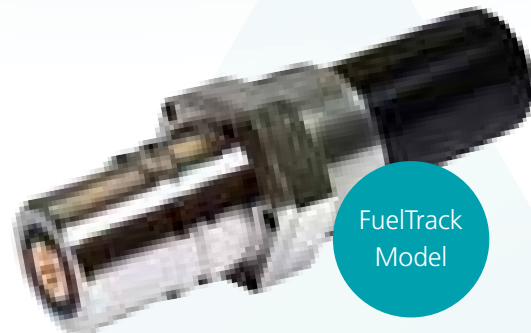
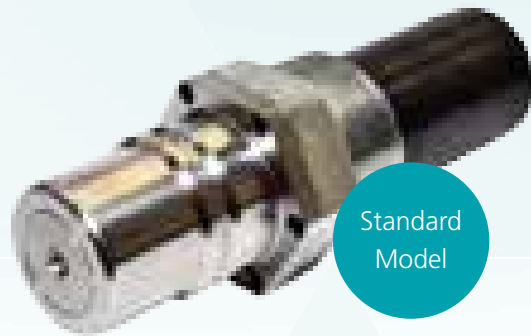

# OIL COUPLINGS

## LUBECENTRAL™ FLUSH FACE RANGE

Banlaw's newest range of couplings, the Flush Face series makes it simpler to ensure zero contamination from site related dirt and cross contamination.

The Flush Face coupling is designed to enable the operator to wipe the coupling face clean before engaging in the transfer hose. No exposed recesses means that only clean oil, grease or other fluid is transferred from the service unit to machine.

## ON VEHICLE LOCATIONS FOR LUBECENTRAL SERVICE

Layout of service box can be designed to suit customer requirements.

## HIGHER FLOW CAPABILITY TO PROVIDE MORE EFFICIENT SERVICE INTERVALS

- The fittings are physically larger in size – up to 1-1/4".
- Available in NPT thread sizes to suit both current industry specifications and larger configurations to maximise the flow rate capability.
- Sound engineering design of the internal fluid flow path.

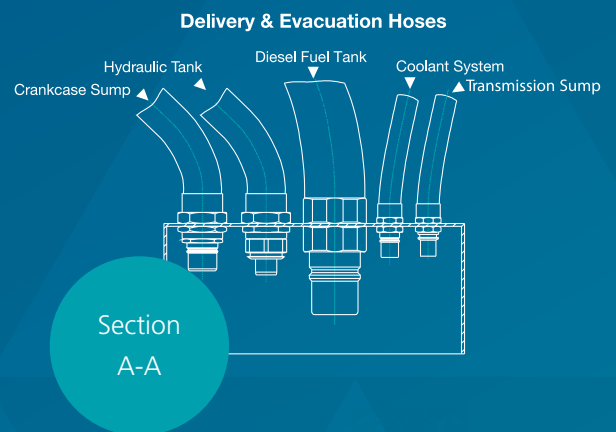



## FLUSH FACE TO MINIMISE CONTAMINATION

Both the nozzle and mating receiver are a “flush face” design, without the traditional recesses to trap harmful contamination between mating fittings. This minimises the extent of contamination entering the fluid stream during servicing and reduces wear on mating seals and other components within the fittings.

## PUSH-TO-CONNECT

Without the need to manually retract the nozzle actuating collar during connection, the operator needn't struggle to ensure proper engagement of the fittings.

## COLOUR CODED

Each set is uniquely colour coded to assist the operator in identifying mating fittings.

## BANLAW DURABILITY

Unlike some other fittings on the market, this new range is “designed for the job”. It retains the trademark Banlaw features including the secure ball-lock latching mechanism and rugged electroplated steel construction of vital parts. This maximises the working life of each fitting and provides a safer work environment for the operator.

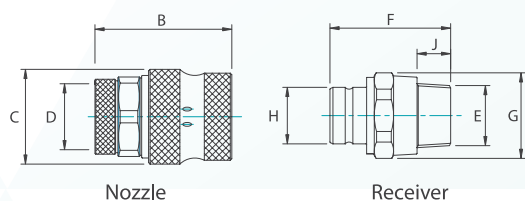

Nozzle

Receiver

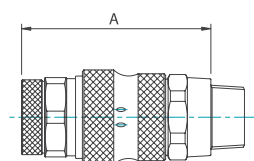

Nozzle and Receiver Connected



## FLUSH FACE THREAD SIZES

Size	Colour	Thread	Receiver (Male) Dim. E		Nozzle (Female) Dim. D		Manufactured from and Application
0	Silver	BSPT	¼"		¼"		Stainless Steel Water
1	Brass	NPT	½"	¾"	¾"	1"	Brass Compatible coolants and water
2	Gold	NPT	¾"	1"	¾"	1"	Zinc plated steel and anodised aluminium Common lubricants and diesel fuel
3	Red						
4	Black						
5	Green						
7	Purple						
8	Platinum						
9	Bronze						
10	Orange						
6	Blue	NPT	1"	1 ¼"	1"	1 ¼"	As above plus may be used with Unleaded Petrol

Note: NPT Thread Supplied as Standard

## FLUSH FACE PRESSURES

		Size 1		Size 2		Size 3		Size 4		Size 5		Size 6	
		N	C	N	C	N	C	N	C	N	C	N	C
SWP	MPa	6.5	6	10	8.75	6.75	8.75	6.5	7	7	5	5	4.5
	psi	943	870	1450	1269	979	1269	943	1015	1015	725	725	653
BP	MPa	26	24	40	35	27	35	26	28	28	20	20	18
	psi	3771	3481	5801	5076	3916	5076	3771	4061	4061	2901	2901	2611
		Size 7		Size 8		Size 9		Size 10					
SWP	MPa	12.63	8.88	11.00	11.25	11.75	9.50	8.25	11.25				
	psi	1832	1288	1595	1632	1704	1378	1197	1632				
BP	MPa	50.5	35.5	44.0	45.0	47.0	38.0	33.0	47.0				
	psi	7324	5149	6382	6527	6817	5511	4786	6817				

**Legend**

- SWP Safe Working Pressure (Maximum Recommended Working Pressure)
- BP Burst Pressure (Minimum Pressure at which Failure Will Occur)
- N Nozzle
- C Nozzle and Receiver Coupled



# OIL COUPLINGS (CONT.)

## LUBECENTRAL™ CLASSIC RANGE

Where high speed transfer rates are not suitable, or unnecessary, Banlaw's Standard couplings are the best solution. A unique coupling is provided for each oil, grease or coolant type, eliminating the possibility of errors during fluid hangouts.

### CRANKCASE

- Fill and evacuate crankcase oils
- Safe Working Pressures;  
AUS27W: 10 MPa (1450 psi)  
AUS29W & AUS29L: 3 MPa (435 psi)  
Coupled Nozzle & Receiver: 4.75 MPa (690 psi)



AUS27W & AUS29W with optional Caps/Plugs

### TRANSMISSION

- Fill and evacuate transmission oils
- Safe Working Pressures;  
AUS32W: 4.25 MPa (615 psi)  
AUS33W: 10 MPa (1450 psi)  
Coupled Nozzle & Receiver: 11.5 MPa (1670 psi)



AUS32W & AUS33W with optional Caps/Plugs

### HYDRAULIC

- Fill and evacuate hydraulic oils
- Safe Working Pressures;  
AUS34A: 10 MPa (1450 psi)  
AUS41A: 10 MPa (1450 psi)  
Coupled Nozzle & Receiver: 4.0 MPa (580 psi)



AUS34A & AUS41A with optional Caps/Plugs

### COOLANT

- Fill and evacuate coolant fluids
- Safe Working Pressures;  
AUS36A: 10 MPa (1450 psi)  
AUS37W: 10 MPa (1450 psi)  
Coupled Nozzle & Receiver: 7.5 MPa (1090 psi)

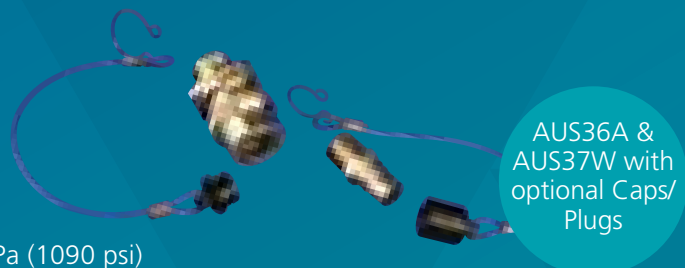

AUS36A & AUS37W with optional Caps/Plugs



## PUSH-TO-CONNECT

- Fill and evacuate oils
- Safe Working Pressures;  
AUS38W: 10 MPa (1450 psi)  
AUS39W: 1.5 MPA (217 psi)  
Coupled Nozzle & Receiver: 10 MPa (1450 psi)



AUS39W &  
AUS38W  
with optional  
Caps/Plugs

## ALTERNATIVE FITTINGS

- Alternative higher flow fittings used to fill and evacuate oils
- Safe Working Pressures;  
AUS80A: 6 MPa (870 psi) - R18 equivalent  
AUS81A: 2.5 MPA (365 psi) - R17 equivalent  
Coupled Nozzle & Receiver: 2.5 MPa (365 psi)

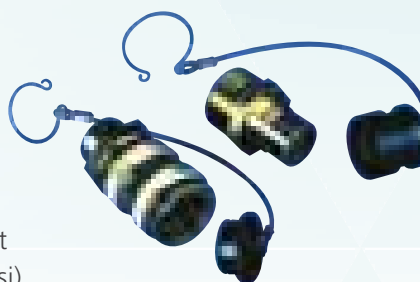

AUS81A &  
AUS80A  
with optional  
Caps/Plugs

## PART NUMBERS

Type	Basic Fitting	Tailpiece			Additional Part	
		1/2" NPT	3/4" NPT	1-1/16" JIC	Plug	Cap
Crankcase	AUS27W	27W-B	STD	27WB/H	-	AUS27W-C
	AUS29W	29W-B	STD	29WB/H	AUS29W-P	-
	AUS29L	29L-B	STD	29LB/H	AUS29L-P	-
Transmission	AUS32W	32W-B	STD	32WB/H	AUS32W-P	-
	AUS33W	STD	-	33WB/H	-	AUS33W-C
Hydraulic	AUS34A	*	STD	34AB/H	AUS34A-P	-
	AUS41A	*	STD	41AB/H	-	AUS41A-C
Coolant	AUS36A	36A-B	STD	36AB/H	AUS36A-P	-
	AUS37W	STD	-	37WB/H	-	AUS37W-C
Push-to-connect	AUS38W	*	STD	38WB/H	-	AUS38W-C
	AUS39W	*	STD	39WB/H	-	-
Alternative	AUS80A	-	-	-	-	AUS80A-C
	AUS81A	-	-	-	AUS81A-P	-

\* Not Standard Product - But can be supplied on request.  
Standard: supplied as standard - option not applicable

## ADDITIONAL ITEMS



AUSGR  
Grease  
Receiver



AUSGN  
Grease  
Nozzle



AUS3W  
One Way  
Valve



AUSV3  
Oil Sample  
Valve

# UNDERGROUND REFUELLING

## UNDERGROUND AUTOMATIC DRY BREAK REFUELLING

Banlaw pioneered 'Dry Break' refuelling for black coal underground applications in the 1980's and continues to provide a range of quality products to this market today.

Banlaw's AUS45 is a dry break nozzle that offers both dry break disconnection (no spill) and automatic shut off once the tank is full when combined with the AUS46 fuel receiver and the AUS25E underground tank vent. Manufactured without using aluminium, all items are safe for black coal underground use.

Extensive testing and field use sees these couplings able to offer fuel dispensing rates of 80 to 400 litres per minute, improving efficiencies with the safety of the dry break latching feature.

Many operators make the change to the Banlaw fuelling components to improve fuelling efficiencies but more importantly improve on fuel cleanliness in equipment tanks.

Dirty water, mud and dust entering fuel tanks through damaged and missing manual fuel caps is a major cause of vehicle unreliability and down time. Contaminated fuel causes blocked fuel filters, damaged injector pumps and ultimately premature engine failures.

## AUS45 NOZZLE

- Flowrate range for Diesel: 90-800 LPM / 24-211GPM
- Mass (with plug): 3.4kg (7.5lbs)



AUS45

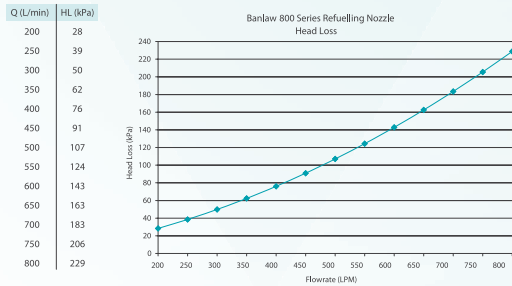

LEGEND:  
 1) All flow tests conducted using DIESOLINE fuel (SG=0.84, 5.5cSt nom.)  
 2) Head Loss (HL) includes Banlaw AUS23 Receiver (results will vary with other make)  
 3) All gauge pressure measured within 2" bore



AUS46 Receiver



AUS46 Shell



AUS25E



AUS25AA-1

# CONTACT US TODAY

## HEAD OFFICE – SALES AND MANUFACTURING FACILITY

Phone: +61 2 4922 6300

Fax: +61 2 4920 6171

Email: [sales@banlaw.com.au](mailto:sales@banlaw.com.au)

25 Metro Court  
Gateshead, NSW 2290 Australia

## WESTERN AUSTRALIA

Phone: +61 8 9209 1351

Fax: +61 2 4920 6171

Email: [sales@banlaw.com.au](mailto:sales@banlaw.com.au)

28 Milly Court  
Malaga, WA 6090 Australia

9/9 Murrena St  
Wedgefield WA 6721 Australia

16/46 Great Eastern Highway  
Kalgoorlie WA 6430 Australia

ABN: 88 062 044 071



## QUEENSLAND

Phone: +61 7 4800 4949

Email: [sales@banlaw.com.au](mailto:sales@banlaw.com.au)

## UNITED STATES

Phone: +1 (775) 340 6414

Fax: +1 (775) 754 2805

Email: [salesna@banlaw.com](mailto:salesna@banlaw.com)

3025 Griffin Street  
Carlin, Nevada 89822  
United States of America

FOR A LIST OF BANLAW'S  
**GLOBAL DISTRIBUTORS AND PARTNERS**

VISIT OUR WEBSITE AT  
[WWW.BANLAW.COM](http://WWW.BANLAW.COM)



Pioneers of  
Unified Fuel  
Management

[banlaw.com](http://banlaw.com)